

## Joseph Sinkovitz Jr.

Joseph Jr. was born in Budapest, Hungary on 01 February 1883. He immigrated to America in 1903 and he indeed arrived prior to his father. His Petition for Naturalization, dated 20 March 1909 and shown on the following page holds some interesting answers. First, the record shows he immigrated to this country from Hamburg, Germany on 03 July 1903 and arrived in New York on the vessel, *First Bismarck*. He states he was living in New Brighton, Pennsylvania and was married and his wife's name was Irene. Cousin Jack Loder recalled to me that Joseph was first married to Irene and that they had a child. He recalled they soon afterward divorced and that he subsequently lost track of the whereabouts of his child. I am still attempting to locate marriage and birth records to substantiate the above oral history.

Joseph apparently worked in a foundry (perhaps with his father) while attending a Technical Design/Drafting School at night, apparently through the correspondence school that Jack Loder mentions in his notes. He lived in nearby New Brighton, Pennsylvania.

I have not found a ship manifest for the *First Bismarck* that would confirm his travel that he testified to in his Petition. Perhaps he was a stowaway or ship hand on this vessel.

The history I have here is meager, but Joseph apparently was very active in his engineering, design and patent work prior to hiring on with Miller Printing Equipment Co.

Some of the early history I currently have on Joseph Jr. is chronologized as follows:

Born: 01 Jan/Feb 1883 in Kispest Hungary  
Immigrated to America: 11 July 1903 (age 20)  
Worked as moulder, attended drafting night school: 1903-1908  
Patent filed for an Air Ship: 10 December 1908 (age 25)  
Married to Irene Unknown: > 1905, < 1909  
Petitioned for Naturalization: 20 March 1909 (age 24)  
Residence on 20 March 1909: New Brighton, PA  
Had no children in 1909  
Child born to Irene and Joseph: >1909  
Occupation in March, 1909: Moulder  
Divorced from Irene: < 1912  
Married Julia Ramold: 1913 (age 30)  
3 Children with Julia Ramold  
Patent No. 1,352,797 for a Crushing Machine: 1920 (age 37)  
Started with Miller Printing Equipment Co.: 1936 (age 53)  
Retired from Miller Printing Equipment Co.: 1950 (age 67)

Joseph's Petition for Naturalization is shown on the following page.

**UNITED STATES OF AMERICA**  
 Department of Commerce and Labor  
 BUREAU OF IMMIGRATION AND NATURALIZATION  
 DIVISION OF NATURALIZATION

**PETITION FOR NATURALIZATION**

UNITED STATES DIST. Court of WEST DIST. PENNA.

In the matter of the petition of Joseph Sinkovitz Jr. to be admitted a citizen of the United States of America.

The petition of Joseph Sinkovitz respectfully shows:

First. My full name is Joseph Sinkovitz

Second. My place of residence is number Corner 7th & 3rd street City of New Brighton PENNSYLVANIA

Third. My occupation is Iron moulder

Fourth. I was born on the 1 day of January, anno Domini 1883, at Kispest Hungary

Fifth. I emigrated to the United States from HAMBURG GERMANY, on or about the 3 day of JULY, anno Domini 1903, and arrived at the port of NEW YORK in the United States, on the vessel Third Bramarck

Sixth. I declared my intention to become a citizen of the United States on the 27 day of DECEMBER, anno Domini 1911 at PITTSBURGH PENNSYLVANIA, in the Eastern Division Court of Allegheny County

Seventh. I am married. My wife's name is Anna Sinkovitz and now resides at New Brighton PENNSYLVANIA. I have no children, and the names, date and place of birth, and place of residence of each of said children is as follows:

Eighth. I am not a disbeliever in or opposed to organized government or a member of or affiliated with any organization or body of persons teaching disbelief in organized government. I am not a polygamist nor a believer in the practice of polygamy. I am attached to the principles of the Constitution of the United States, and it is my intention to become a citizen of the United States and to renounce absolutely and forever all allegiances and fidelity to any foreign prince, potentate, state, or sovereignty, and particularly to FRANCIS JOSEPH, APOSTOLIC KING OF HUNGARY, of which at this time I am a subject, and it is my intention to reside permanently in the United States.

Ninth. I am able to speak the English language.

Tenth. I have resided continuously in the United States of America for a term of five years at least immediately preceding the date of this petition, to wit, since the 11 day of JULY, anno Domini 1903, and in the City of PENNSYLVANIA for one year at least next preceding the date of this petition, to wit, since the 12 day of JULY, anno Domini 1903.

Eleventh. I have not heretofore made petition for citizenship to any court. I made petition for citizenship to the County of Allegheny on the 27 day of DECEMBER, anno Domini 1911, and the petition was denied by the said Court for the following reasons and cause, to wit: and the cause of such denial has since been cured and removed.

Twelfth. I have attached hereto and made a part of this petition my declaration of intention to become a citizen of the United States and the certificate from the Department of Commerce and Labor required by law. Wherefore your petitioner prays that he may be admitted a citizen of the United States of America.

Date MARCH 20 1909 Joseph Sinkovitz Jr. (Signature of petitioner)

UNITED STATES OF AMERICA  
 WESTERN DISTRICT OF PENNSYLVANIA  
Joseph Sinkovitz Jr., being duly sworn, deposes and says that he is the petitioner in the above-entitled proceeding; that he has read and understands the contents thereof; that the same is true to his own knowledge, except as to matters therein stated to be alleged upon information and belief, and as to those matters he believes it to be true.

Subscribed and sworn to before me this 20 day of MARCH, anno Domini 1909  
 WILLIAM T. LINDSEY, Clerk. (Seal.)  
 By J. H. Haggard ASSISTANT Clerk.

\*If the alien arrived otherwise than by steam, the character, name or name of transportation company should be given.

Declaration of Intention and Certificate of Landing from Department of Commerce and Labor filed this 20 day of MARCH, 1909  
 WILLIAM T. LINDSEY, Clerk.  
 By J. H. Haggard ASSISTANT Clerk.

**AFFIDAVIT OF WITNESSES**  
 UNITED STATES DIST. Court of WEST DIST. PENNA.  
 In the matter of the petition of Joseph Sinkovitz Jr. to be admitted a citizen of the United States of America.

UNITED STATES OF AMERICA  
 WESTERN DISTRICT OF PENNSYLVANIA  
S. W. Biking occupation Moulder residing at New Brighton Pa.  
J. A. Kiefer occupation Iron moulder residing at New Brighton Pa.

Each being severally duly and respectively sworn, deposes and says that he is a citizen of the United States of America; that he has personally known Joseph Sinkovitz Jr., the petitioner above mentioned, to be a resident of the United States for a period of at least 5 years continuously immediately preceding the date of filing his petition, and of the County in which the above-entitled application is made for a period of 1 year continuously immediately preceding the date of filing his petition; and that he has personal knowledge that the said petitioner is a person of good moral character, attached to the principles of the Constitution of the United States, and that he is in every way qualified, in his opinion, to be admitted a citizen of the United States.

Subscribed and sworn to before me this 20 day of MARCH, anno Domini 1909  
 WILLIAM T. LINDSEY, Clerk.  
 By J. H. Haggard ASSISTANT Clerk.

Petition for Naturalization for Joseph Sinkovitz Jr., 20 March 1909

In the above *Petition for Naturalization* Joseph states his wife's name as Irene Sinkovitz and that he was born in Budapest, Hungary and now resides in New Brighton, Pennsylvania. I believed initially that there were two Joseph Sinkovitz's. I raised the question with my cousin, Jack Edward Loder.

According to Jack, his grandfather, Joseph Sinkovitz Jr., shared with him that he had been married prior to his marriage with his Grandmother, Julia Ramold. Joseph had married an Irene and bore a child through the marriage.

*"I've tried to pass some of his wisdom down to my children. My mother once told me that her father, Joseph Jr., was married once before he married Julia. When I asked Grampap about it, his gray eyes clouded over and he said, 'Yes,' he was, 'but that was a long time ago.' Her name was Irene and they had a child. But he never said much more about it. That was something he didn't talk about. I don't know if they got divorced or what, but it would have been shortly after his arrival."*

*Ref: Personal notes received from Jack E. Loder, Dated 24 March 2012.*

## **Marriage of Joseph Sinkovitz Jr. and Irene Unknown**

My research quest could not be quenched and I set forth to explore this otherwise unknown, Irene Sinkovitz. I did, thereafter, locate an Irenia Sinkovitz seeking *Citizenship to the United States through the Naturalization of One's Husband*. (See next page.)

Irene (Irenia) Sinkovitz states in her "Emergency Passport Application" that she had lived in New Brighton, Pennsylvania from 1905 to 1908 (where she and Joseph had lived) and had later moved to Gary, Indiana, where she worked as a "Housekeeper". She states that she had left the United States on 12 September 1909 and had been residing in Kispest, Hungary, since 25 September 1909 and intended to return to the United States within 10 days. Irenia states her desire for the passport was... "to return to America." Irenia attests that her husband (Joseph) immigrated to the United States on board the Kiser Wilhelm II from Hamburg on 11 July 1902 and that he resided in the United States 8 years uninterruptedly from 1902 to 1910 at New Brighton, Pennsylvania. Apparently, Irene received her passport to return to America but failed to obtain her citizenship.

Irene is next found in Los Angeles, California in 1922 working as a trained nurse and was petitioning for Naturalization. She states she was born 25 August 1888 was "*not married*", but her husband "*was Joseph*" and that he was "*deceased*". She states she immigrated to the United States on 05 September 1905 on the vessel *Slavonia*. She states she had no children and had resided in the United States since 11 October 1905 and lived in the State of California since 30 November 1920. She signed her name Irene Irma Sienkovitz. Her naturalization was approved on 31 May 1927.

Duplicate  
(FORM NO. 178--CONSULAR.)

Fee for Passport, - - - \$1.00  
Fee for administering oath  
and preparing passport  
application, - - - - - 1.00

PERSON CLAIMING CITIZENSHIP THROUGH NATURALIZATION OF HUSBAND OR PARENT.

No. 63 Issued, 13 August, 1910.  
I, Irene Sinkovitz, a naturalized and loyal citizen of the United States, hereby apply to the American Embassy at Budapest, Hungary for a passport for myself, accompanied by my wife, and minor children, as follows: born at \_\_\_\_\_, on the \_\_\_\_\_ day of \_\_\_\_\_, 1910; and

I solemnly swear that I was born at Budapest, Hungary on or about the 25th day of August, 1888; that my husband emigrated to the United States, sailing on board the "Harzer Wilhelm" from Bamberg, on or about the 11th day of July, 1902; that he resided 8 years, uninterruptedly, in the United States, from 1902 to 1910, at New Brighton; that he was naturalized as a citizen of the United States before the District Court of Western Pennsylvania, at Pittsburgh, on the 10th day of July, 1909, as shown by the accompanying Certificate of Naturalization; that I am the wife of the person described in said Certificate; ~~that I am the bearer of~~ Passport No. \_\_\_\_\_, issued by \_\_\_\_\_, on the \_\_\_\_\_ day of \_\_\_\_\_, 1910, which is returned herewith; that I am the identical ~~person referred to in said passport~~; that I have resided in the United States, uninterruptedly, for 3 years, from 1908 to 1908, at New Brighton; that I am domiciled in the United States, my permanent residence being at Gary, in the State of Indiana, where I follow the occupation of house-keeping; that I last left the United States on the 18th day of September, 1909, on board the "Harzer Wilhelm", arriving in Bamberg the 23rd day of September, 1909; that I have resided in Budapest, Hungary since the 25th day of September, 1909; that I am now temporarily residing at Budapest, Hungary; and that I intend to return to the United States within 10 days with a purpose of residing and performing the duties of citizenship therein.

I have not applied for a United States passport elsewhere and been refused.  
I desire the passport for the purpose of returning to America.

OATH OF ALLEGIANCE.

Further, I do solemnly swear that I will support and defend the Constitution of the United States against all enemies, foreign and domestic; that I will bear true faith and allegiance to the same; and that I take this obligation freely, without any mental reservation or purpose of evasion: So help me God.

Irene Sinkovitz  
AMERICAN Consulate General AT BUDAPEST, Hungary  
Sworn to before me, this 13th day of August, 1910.  
H. Bennett  
Vice and Deputy Consul General



N.S. 372/1910

DESCRIPTION OF APPLICANT.

Age: 22 years. Mouth: medium  
Stature: 5 feet, 8 inches, Eng. Chin: good  
Forehead: high Hair: brown  
Eyes: dark Complexion: fair  
Nose: regular Face: round

IDENTIFICATION.

I hereby certify that I know the above-named Irene Sinkovitz personally, and know her to be the wife of the person referred to in the within-described Certificate of Naturalization, and that the facts stated in her affidavit are true to the best of my knowledge and belief.  
Hugh Kemmer  
[Address of witness] 704 1/2 St. W., Budapest

Note.—This form is to be filled out in duplicate, one copy being retained on the files of the issuing office and the other forwarded with the quarterly returns to the Department of State.

Irene Sinkovitz's Citizenship Claim based upon her husband's Naturalization

No. 19862

# UNITED STATES OF AMERICA

## PETITION FOR NATURALIZATION

To the Honorable the DISTRICT Court of THE UNITED STATES LOS ANGELES, CALIFORNIA

The petition of IRENE IRMA SIENKOVITZ hereby filed, respectfully sheweth:

First. My place of residence is 5947 Benner St., Los Angeles, California (Give number, street, city or town, and State.)

Second. My occupation is Trained Nurse

Third. I was born on the 25th day of August, anno Domini 1888, at Budapest, Hungary

Fourth. I emigrated to the United States from Piuna, Hungary on or about the 5th day of September anno Domini 1906, and arrived in the United States, at the port of New York, N.Y. on the 11th day of October anno Domini 1906, on the vessel Slavonia

Fifth. I declared my intention to become a citizen of the United States on the 17th day of February anno Domini 1905 at Los Angeles, California in the District Court of the United States

Sixth. I am not married. My husband's name is was Joseph (the) was born on the 1st day of January anno Domini 1885 at Budapest, Hungary and now resides at Los Angeles, California (Give number, street, city or town, and State.)

I have no children, and the name, date, and place of birth, and place of residence of each of said children is as follows:

Seventh. I am not a disbeliever in or opposed to organized government or a member of or affiliated with any organization or body of persons teaching disbelief in or opposed to organized government. I am not a polygamist nor a believer in the practice of polygamy. I am attached to the principles of the Constitution of the United States, and it is my intention to become a citizen of the United States and to renounce absolutely and forever all allegiance and fidelity to any foreign prince, potentate, state, or sovereignty, and particularly to THE PRESENT GOVERNMENT OF HUNGARY of whom at this time I am a subject, and it is my intention to reside permanently in the United States.

Eighth. I am able to speak the English language.

Ninth. I have resided continuously in the United States of America for the term of five years at least immediately preceding the date of this petition, to wit, since the 11th day of October anno Domini 1906, and in the State of California continuously next preceding the date of this petition, since the 20th day of November anno Domini 1920, being a residence within this State of at least one year next preceding the date of this petition.

Tenth. I have not heretofore made petition for citizenship to any court. (If made petition for citizenship to any court, state the date, name of court, and the name of such court, and whether the same was granted or refused.)

Attached hereto and made a part of this petition are my declaration of intention to become a citizen of the United States and the certificate from the Department of Labor, together with my affidavits and the affidavits of the two verifying witnesses thereto, required by law. Wherefore your petitioner prays that he may be admitted a citizen of the United States of America.

*Irene Irma Sienkovitz*  
(Complete and true signature of petitioner.)

Declaration of Intention No. 52155 and Certificate of Arrival from Department of Labor filed this 31st day of May, 1922.  
How to Check on Cases.—If petitioner arrived in the United States or on various parts of, 1900, strike out the words reading "and Certificate of Arrival from Department of Labor."

### AFFIDAVITS OF PETITIONER AND WITNESSES

UNITED STATES OF AMERICA  
SOUTHERN DISTRICT OF CALIFORNIA

The undersigned petitioner being duly sworn, deposes and says that he is the petitioner in the above-entitled proceedings; that he has read the foregoing petition and knows the contents thereof; that the said petition is signed with his full, true name; that the same is true of his own knowledge, except as to matters therein stated to be alleged upon information and belief; and that as to those matters he believes it to be true.

*Irene Irma Sienkovitz*  
(Complete and true signature of petitioner.)

August Jacobs occupation Builder residing at 5947 Benner St., L.A.  
and Mary H. Beauchamp occupation Nurse residing at 6229 1/2 Pasadena Ave., L.A.

Irene Irma Sienkovitz the petitioner above mentioned, to have resided in the United States continuously immediately preceding the date of filing his petition, since the 30th day of May anno Domini 1922, and in the State in which the above-entitled petition is made continuously since the 30th day of May anno Domini 1922; and that he has personal knowledge that the said petitioner is a person of good moral character, attached to the principles of the Constitution of the United States, and that the petitioner is, in his own right, entitled, in his opinion, to be admitted a citizen of the United States.

*August Jacobs*  
*Mary H. Beauchamp*  
(Complete and true signatures of witnesses.)

Subscribed and sworn to before me by the above-named petitioner and witnesses in the office of the Clerk of said Court this 31st day of May anno Domini 1922

R. S. ZIMMERMAN  
Clerk

No. 75714



August, 1910  
Petition for Naturalization for Irene Irma Sienkovitz, 30 May 1922

246

Form 2308  
U. S. DEPARTMENT OF LABOR  
NATURALIZATION SERVICE

TRIPLICATE  
(To be given to the person making  
the Declaration)

No. 32133

19862

# UNITED STATES OF AMERICA

## DECLARATION OF INTENTION

Invalid for all purposes seven years after the date hereof

United States of America,  
Southern District of California, } ss:  
County of Los Angeles

In the District Court of the United States.

I, Irene Irma Sienkovitz, aged 36 years,  
occupation Graduate Nurse, do declare on oath that my personal  
description is: Color White, complexion Fair, height 5 feet 4 inches,  
weight 172 pounds, color of hair Brown, color of eyes Brown  
other visible distinctive marks None

I was born in Budapest, Hungary  
on the 25 day of August, anno Domini 1 888. I now reside  
at 5947 Beuner St., Los Angeles, California.  
(Give number, street, and city or town.)

I emigrated to the United States of America from Trieste, Italy  
on the vessel Slavonia

(If the alien arrived otherwise than by vessel, the place of departure or name of transportation company should be given.)  
my last foreign residence was Budapest, Hungary, I am not married; the name  
of my wife is \_\_\_\_\_; she was born at \_\_\_\_\_  
and now resides at \_\_\_\_\_

It is my bona fide intention to renounce forever all allegiance and fidelity to any foreign  
prince, potentate, state, or sovereignty, and particularly to  
THE PRESENT GOVERNMENT OF HUNGARY.

of whom I am now a subject;  
I arrived at the port of New York  
State of New York on or about the 11th day  
of October, anno Domini 1 925. I am not an anarchist; I am not a  
polygamist nor a believer in the practice of polygamy; and it is my intention in good faith  
to become a citizen of the United States of America and to permanently reside therein:  
SO HELP ME GOD.

Irene Irma Sienkovitz  
(Original signature of declarant.)

Subscribed and sworn to before me in the office of the Clerk of said Court  
at Los Angeles, Cal., this 17 day of Feb  
anno Domini 191 25.

[SEAL]

CHAS. N. WILLIAMS,  
Clerk of the U. S. District Court, Southern District of California.  
By [Signature], Deputy Clerk.

Irene Irma Sienkovitz's Declaration of Intention, 17 February 1925

Irene is also shown in the Los Angeles, California 1930 Federal Census as "Widow", with a female, Miriam Westberg, age 10, living with her and shown to be Irene's cousin. We will likely never learn the details or motivation behind the marriage, pregnancy, separation, and exodus to Hungary, return to America or the final disposition of Irene Sinkovitz and their child.

I trust I have not dwelled too long on the personage of Irene. While Joseph did acknowledge her as his first wife he apparently had sorrow about their marriage. I placed the history herein because records were available and it somewhat closes the history on who she was.

### **Early Patents of Joseph Sinkovitz Jr**

A patent for an Air Ship was filed 10 December 1908 when Joseph was 25 years old. The story Great Grandson, Jack Edward Loder (Anna Elizabeth Sinkovitz's son) was told and related to me is...

*"Joseph had this idea for an Airship that he had patented. He and some others organized a company to begin manufacturing one for test purposes. One of the partners had the responsibility to acquire investment capital prior to prototype production. Apparently, funds were indeed secured by this partner who then took the investment monies and was never heard from again!"*

Joseph Sinkovitz Jr. led a most interesting life from what I have been able to glean. Some of Joseph's personal patents bear the spelling Sinkovits, while others (taken out with Miller) show Sinkovitz.

The first page of Joseph's Patent No. 920,675 dated 04 May 1909 is shown on the next page. Joseph was but 25 when he made application for this patent.

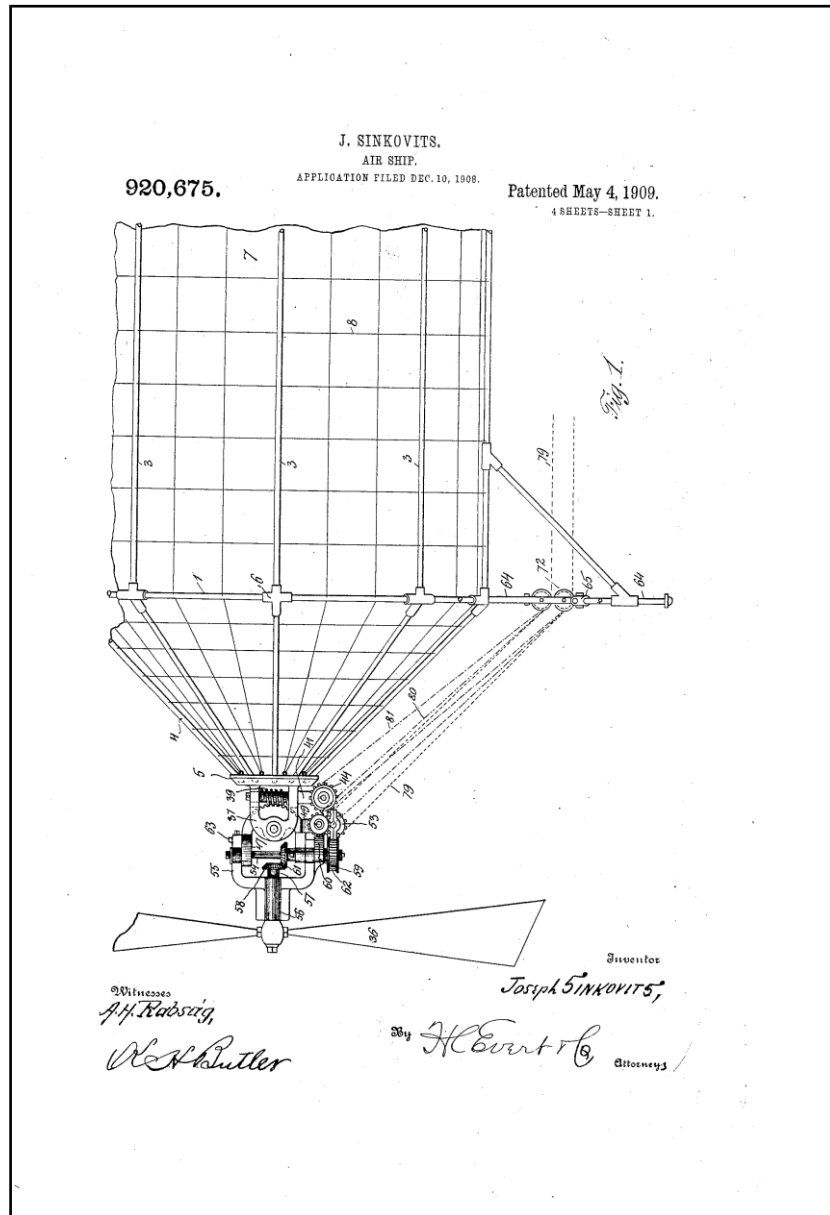

**Joseph Sinkovitz Air Ship Patent 920,675  
04 May 1909**

See file records for the full patent disclosure.

The Sinkovitz patent was dated 28 years prior to the infamous 1937 Hindenburg disaster.

*The Hindenburg disaster took place on Thursday, May 6, 1937, as the German passenger airship LZ 129 Hindenburg caught fire and was destroyed during its attempt to dock with its mooring mast at the Lakehurst Naval Air Station, which is located adjacent to the borough of Lakehurst, New Jersey. Of the 97 people on board (36 passengers, 61 crew), there were 36 fatalities, including one death among the ground crew.*

*The disaster was the subject of spectacular newsreel coverage, photographs, and Herbert Morrison's recorded radio eyewitness report from the landing field, which was broadcast the next day. The actual cause of the fire remains unknown, although a variety of hypotheses have been put forward for both the cause of ignition and the initial fuel for the*



*ensuing fire. The incident shattered public confidence in the giant, passenger-carrying rigid airship and marked the end of the short airship era.*

**Ref:** [http://en.wikipedia.org/wiki/Hindenburg\\_disaster](http://en.wikipedia.org/wiki/Hindenburg_disaster)

The Sinkovitz Air Ship patent did identify lighter than air gases such as hydrogen that were suggested for use. The Hindenburg unfortunately, did utilize hydrogen. We will likely not learn of a relationship between the two ships... if in fact there was one.



**Hindenburg Blimp Crash**  
**Photograph reconstruction of original**

There were no colored photographs at the time this photograph was taken May 6, 1937  
(Unknown source)

In 1920, Joseph was shown as one-half Assignor on a patent No. 1,352,797 for a Crushing Machine assigned to William Elk of Pittsburgh, PA. Joseph may have assisted in some of the engineering and design work to realize his one-half share. Joseph is shown as patenting over 16 other patents during his engineering work with Miller Printing Equipment, Inc. from 1936 to 1950 as discussed later. I have only included front sheets for a few of the patents to his credit. Most of the early patents were in Joseph's name with no assignment. Other later patents were granted to Joseph but assigned to Miller Printing Machinery Co.

<b>Patent No.</b>	<b>Title</b>	<b>Date Filed</b>
2119754	Cylinder Gripper...	01 Apr 1937
2141418	Pile Raise/Lower Mechanism...	25 May 1937
2195533	Sheet Delivery Mechanism...	13 May 1938
2206269	Ink Feeding Device...	01 Apr 1937
2237453	Register Means for Presses...	21 May 1940
2273899	Sheet Delivery Mechanism...	02 Apr 1938
2304855	Material Handling Apparatus...	30 Jun 1941
2307079	Collapsible Platform For Printing...	09 Aug 1941
2353196	Apparatus for Handling...	12 Aug 1941
2363560	Printing Apparatus...	21 Jan 1941
2372229	Sheet Handling Apparatus	10 Oct 1941
2517251	Press Operating Mechanism...	01 Feb 1946
2561423	Inking Mechanism...	30 Mar 1949
2737112	Two Revolution Press...	12 Jan 1952

The above patents show the date the patents were filed...all were granted.

July 2, 1940.

J. SINKOVITZ  
INK FEEDING DEVICE  
Filed April 1, 1937

2,206,269

4 Sheets-Sheet 1

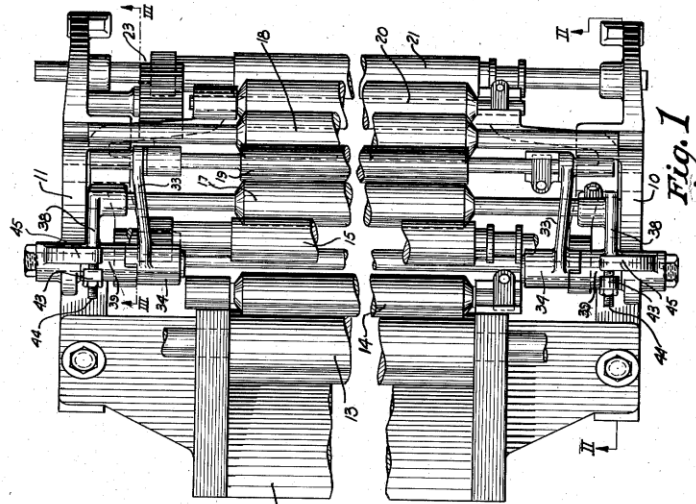

Fig. 1

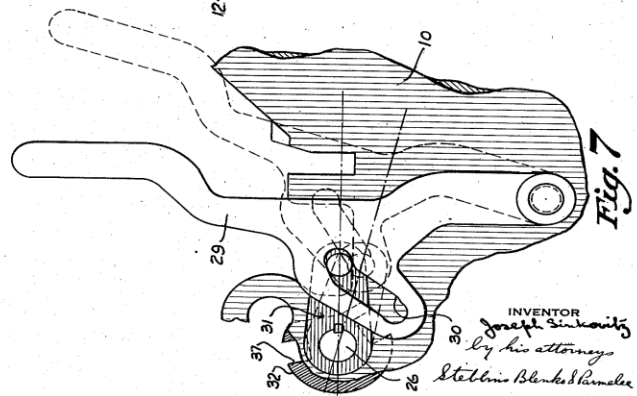
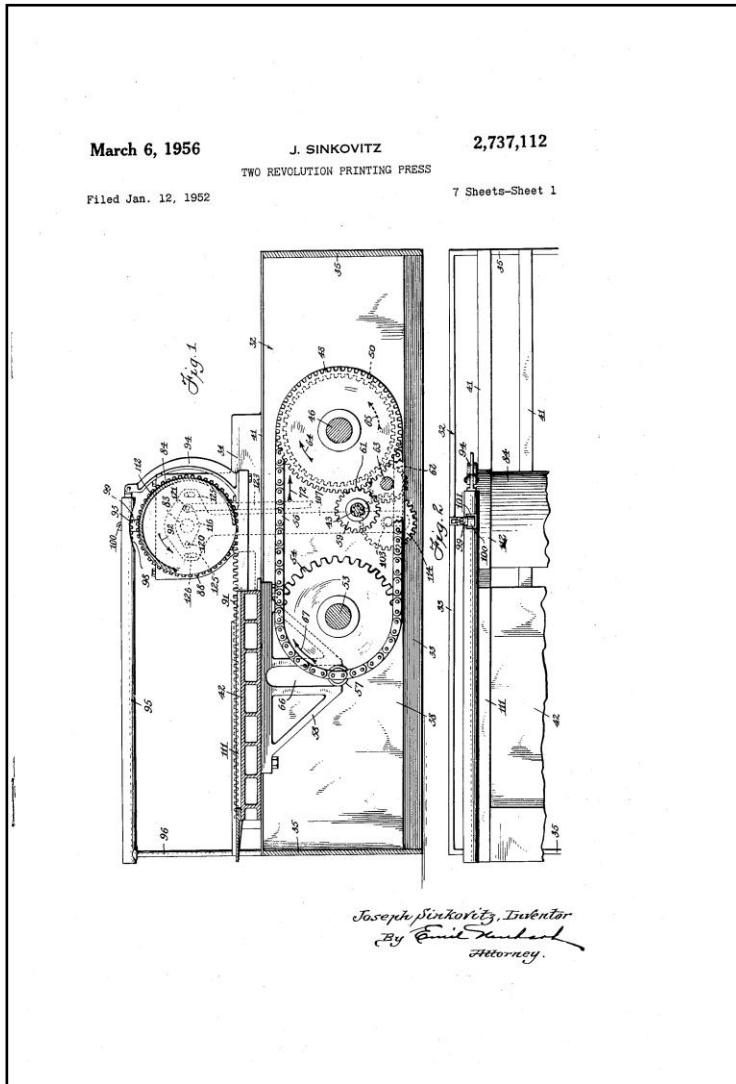

Fig. 7

INVENTOR  
*Joseph Sinkovitz*  
By his attorneys  
*Stellins Blank & Parnell*

Patent 2,206,269 Front Sheet, 1940



**Patent 2,516,423, Front Sheet, 1956**

Note that the above patent was applied for in 1952, two years after Joseph had officially retired. He must have been committed to see his patent succeed to fruition some four years later.

**Joseph Sinkovitz Jr. Marriage to Julia Ramold**

Joseph Jr. married Julia Ramond in 1913 when Joseph was 30 years old and Julia was 17. Julia's mother was Anna Ramold born in Hungary in 1861 and immigrated to this country in 1901. Joseph worked as an Engineer with Miller Printing Machinery Company in Pittsburgh from 02 September 1936 to his retirement on December 31, 1950. He was Miller's Chief Engineer for many years. Miller was purchased by MAN Roland, Inc. who recently (2012) has been acquired by MAN Roland due to a worldwide recession in the printing industry and experienced a severe crisis in the years 2001 until 2004.

In 2002 Man Roland acquired a controlling interest in the software company ppi Media GmbH. ppi Media, headquartered in Hamburg, Germany serves customers worldwide and develops workflow solutions for automated planning and production processes in publishing and printing. ppi Media was founded in 1984 and employs approximately 150 staff at its offices in Hamburg, Kiel and Chicago. Miller made major worldwide contributions to the printing industry including U.S. Treasury paper currency printing, much to the credit of their longstanding Chief Engineer, Joseph Sinkovitz Jr.

A letter from K.O. Kiel, Director of Human Relations at Man Roland, Inc., Westmont, Illinois provided this information and included an original drawing (see pg 49) that Joseph prepared dated 21 April 1939.



Joseph's draftsmanship, calculations, and design work were uncannily similar to my own, and substantiated my general belief that any engineering acumen that I may have inherited was indeed derived from my Hungarian Sinkovitz, not my Scottish Adams, lineage.

Joseph Jr. and Julia had three children:

James Louis born 25 Feb 1914

Anna E. Sinkovitz born 28 Mar 1917

Roy Norman born 13 Nov 1924

1910 census records show that Julia Ramold had been a servant at the Emmer F. Gwynn family, 30 Brigham Street in Pittsburgh, PA.

**Julia Ramold (17) and Joseph Sinkovitz, Jr. (30)**

All of their children were born in or near, Pittsburgh, Pennsylvania where they resided. Joseph and wife, Julia, shown in the above photograph may have been taken during their wedding in 1913. I received the photograph from Jean Liszt Sinkovitz, the wife of James Sinkovitz who was the son of Joseph Jr.

The following record was found in the 1916 City Directory for Pittsburgh, PA through Ancestry.com:

Name:	<b>Joseph Sinkovitz Jr.</b>
Residence Year:	1916
Street Address:	226 Poplar
Residence Place:	Pittsburgh, Pennsylvania
Occupation:	Draftsman
Publication Title:	Pittsburgh, Pennsylvania, City Directory, 1916

We do not know the details of this above drafting employment; however, it was prior to his engineering work at Miller Printing Machinery Co. Joseph may have been performing engineering design/drafting work on his own at this time while attending night school. Joseph would have been married to Julia for three years at this time.

I would have very much enjoyed meeting my Grand Uncle, Joseph Jr., during my own engineering career. I had no knowledge of Joseph's employment or engineering background. I also never met Joseph Sinkovitz Sr. I was only eleven years old when he passed away in Monaca in 1948. At this time our family was then living in St. Charles, Illinois.

Other patents and engineering documents of Joseph are shown on the following pages.

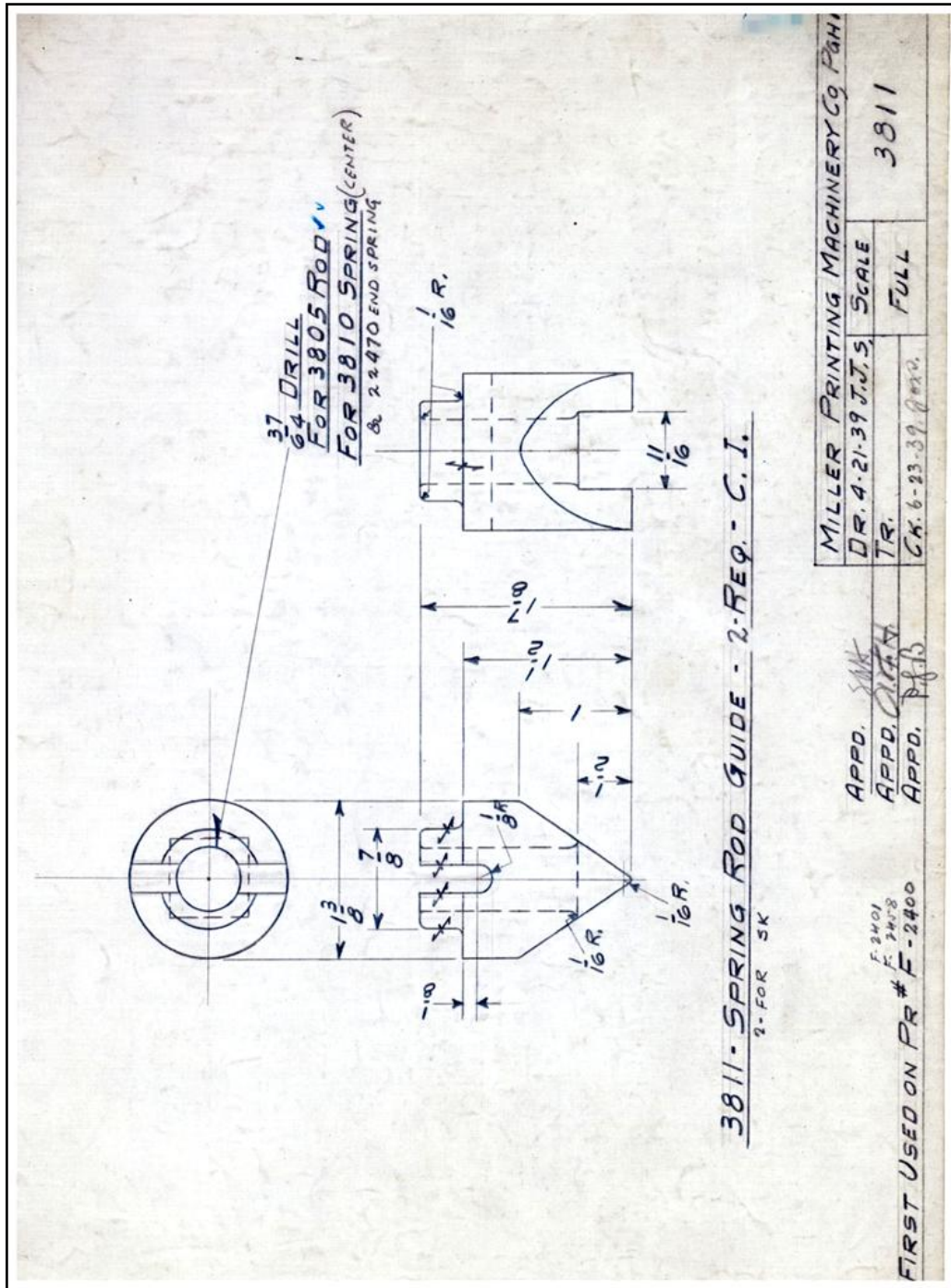

Part Drawing prepared and checked by Joseph Sinkovits, 21 April 1939  
Received 05 July 1971, from Miller Printing Machinery Co.

Joseph's draftsmanship, while standard in the industry, had an uncanny resemblance to my own line work and dimensioning.

April 2, 1940.

S. A. HUFFMAN ET AL

2,195,533

SHEET DELIVERY MECHANISM

Filed May 13, 1938

7 Sheets-Sheet 1

Fig. 1.

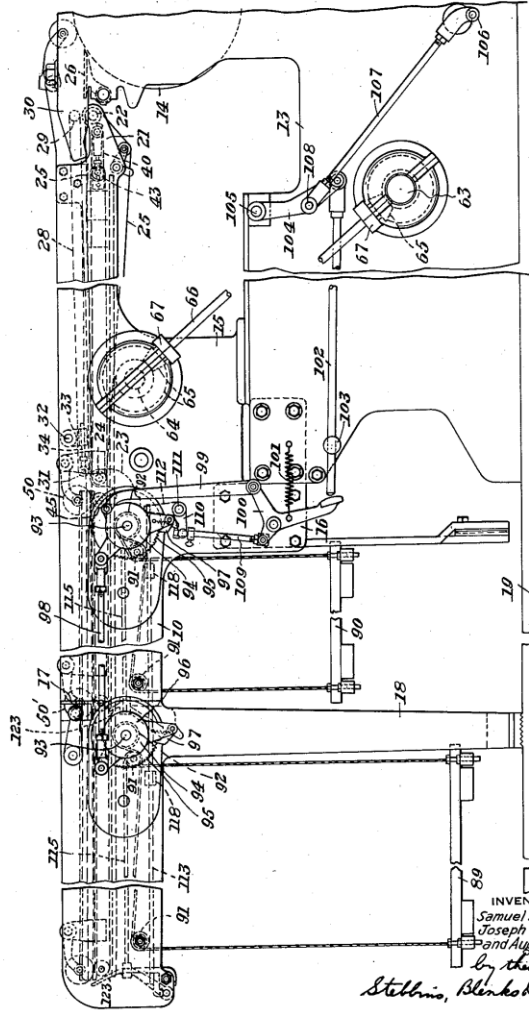

INVENTORS  
Samuel A. Huffman,  
Joseph Sinkovitz  
and August A. Saul  
by their attorneys  
Stebbins, Blenkoch, Kemezis

Joseph Sinkovits Sheet Delivery Patent, 2,195,533, 02 April 1940  
Joseph was working for Miller Printing Equipment at this time



March 6, 1956

J. SINKOVITZ

2,737,112

TWO REVOLUTION PRINTING PRESS

Filed Jan. 12, 1953

7 Sheets-Sheet 1

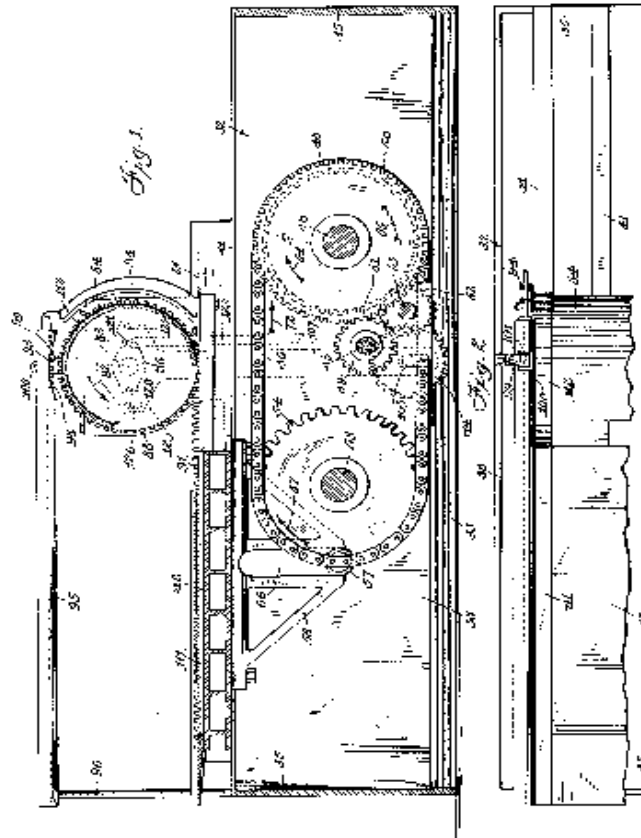

Joseph Sinkovitz, Inventor  
By *Emil Hanko*  
Attorney.

Joseph Sinkovits Two Revolution Printing Press Patent, 2,737,112, 12 Jan 1956  
Joseph had retired from Miller Printing Equipment Co.